



## Visualising Early Design Information

Filippo A. Salustri, Ph.D., P.Eng.  
Jayesh Parmar

Ryerson University  
salustri@ryerson.ca  
<http://deed.ryerson.ca/~fil/>



Where do the doodles go?

## A Vision

- An electronic white board
- Adaptive UI to respond to state & process
- Automatic & instantaneous layout
- Connected to online documentation facility

## Diagrams in Design

- What We've Got:
  - ◆ Downstream stages well served by CAD
  - ◆ Virtually nothing for the early stages.
- How Things Are:
  - ◆ Diagrams often used in early design to visualise, communicate, and record.

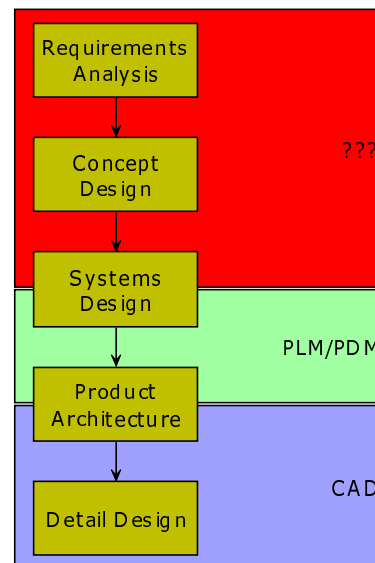

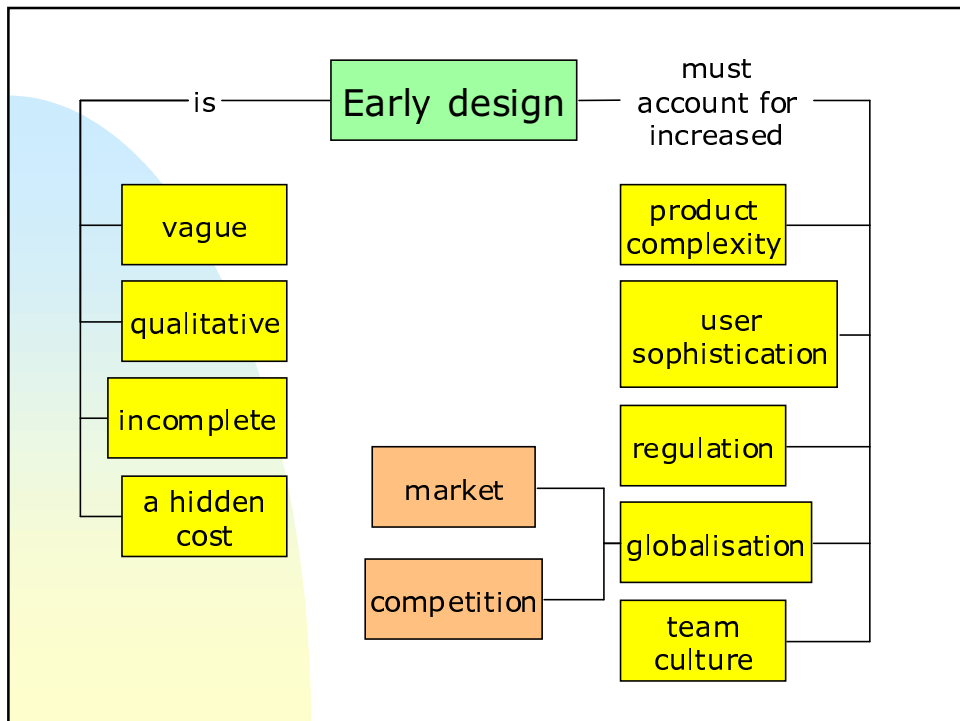
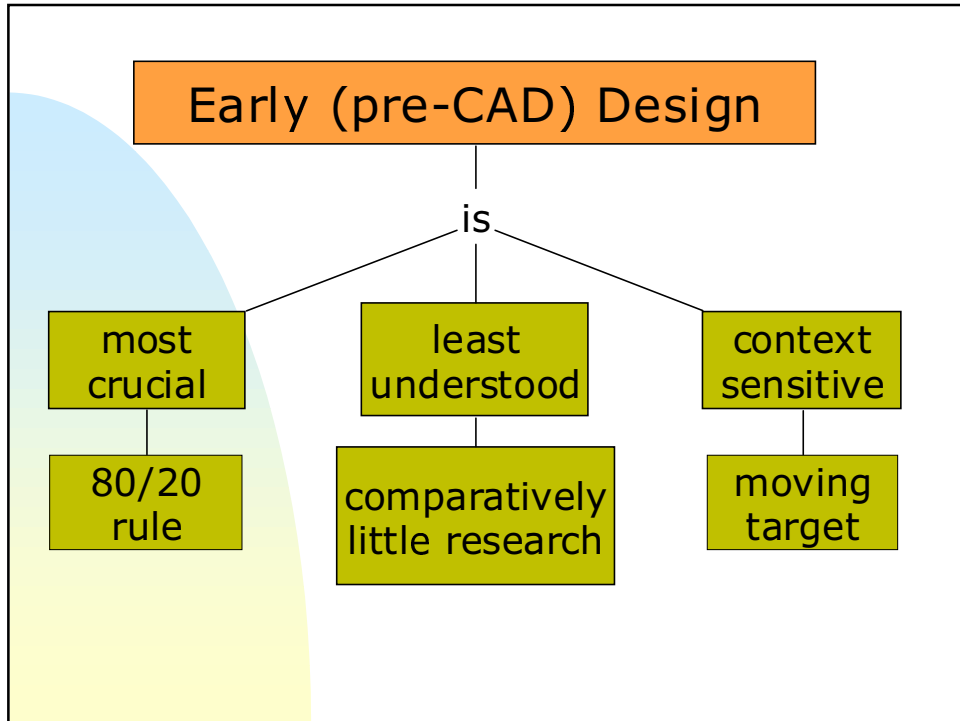

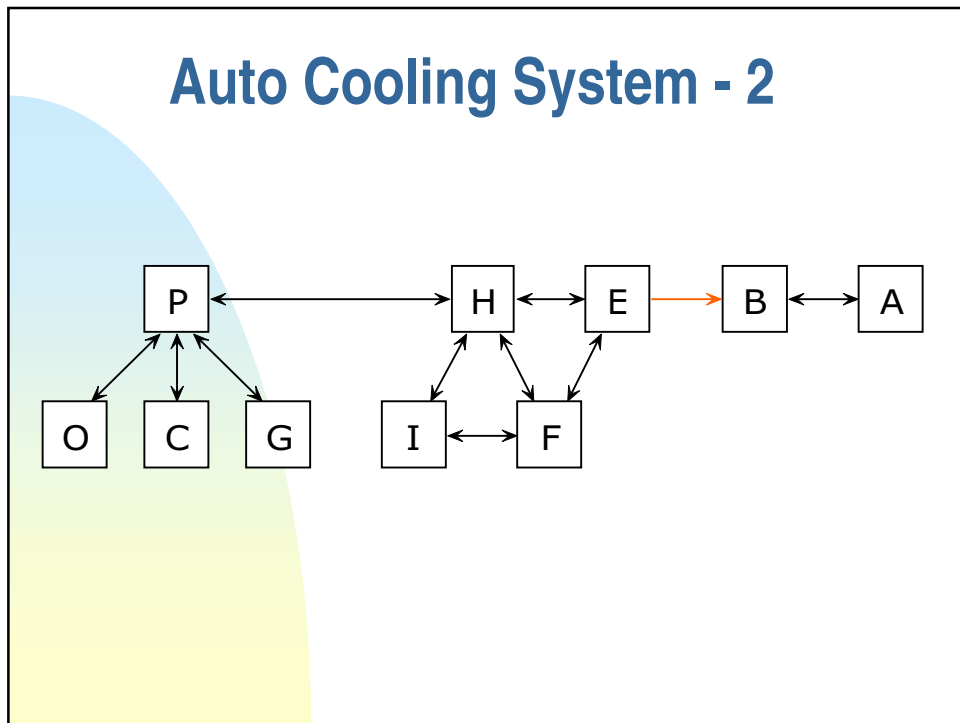
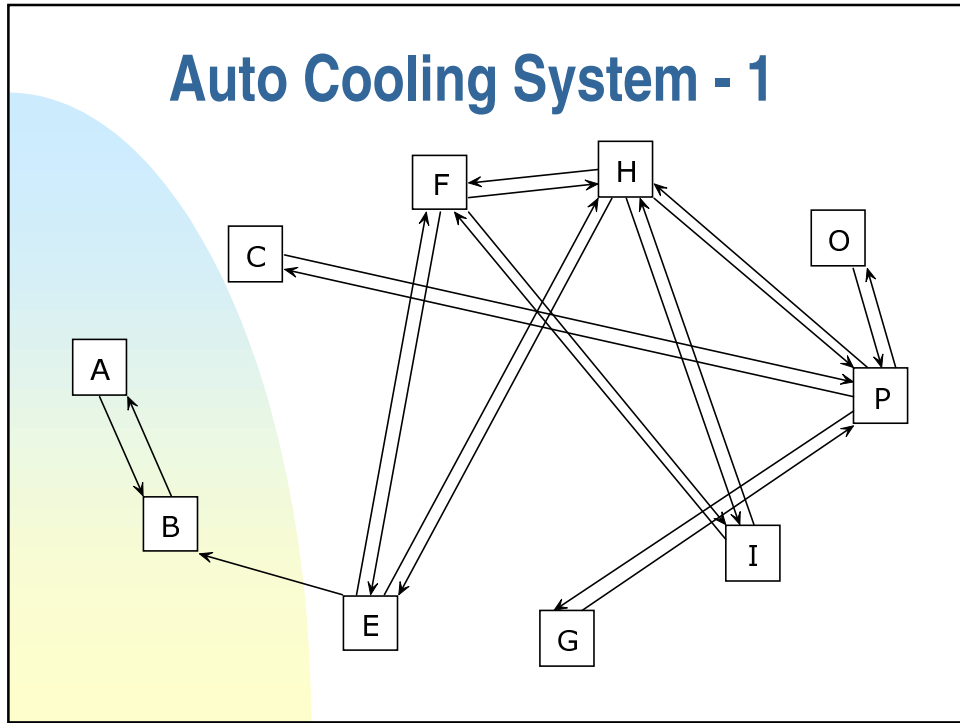

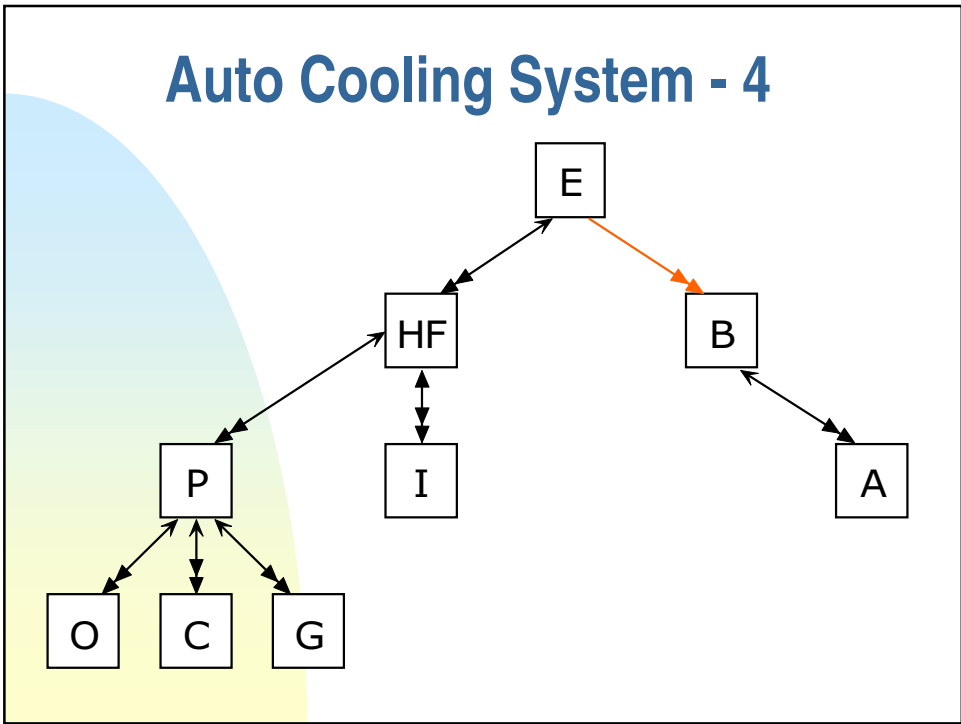
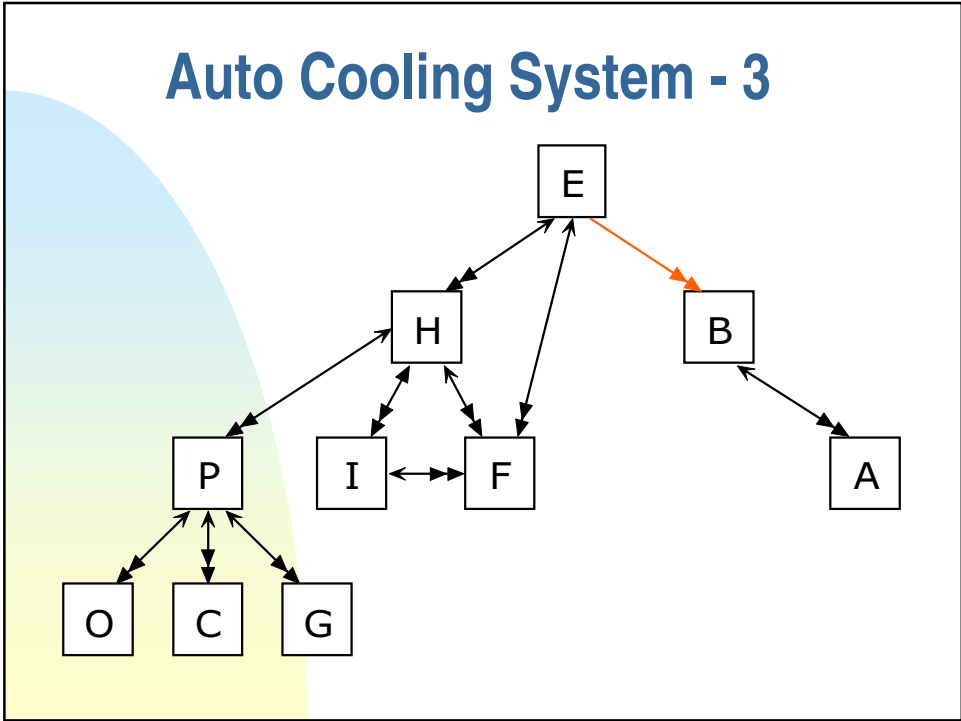

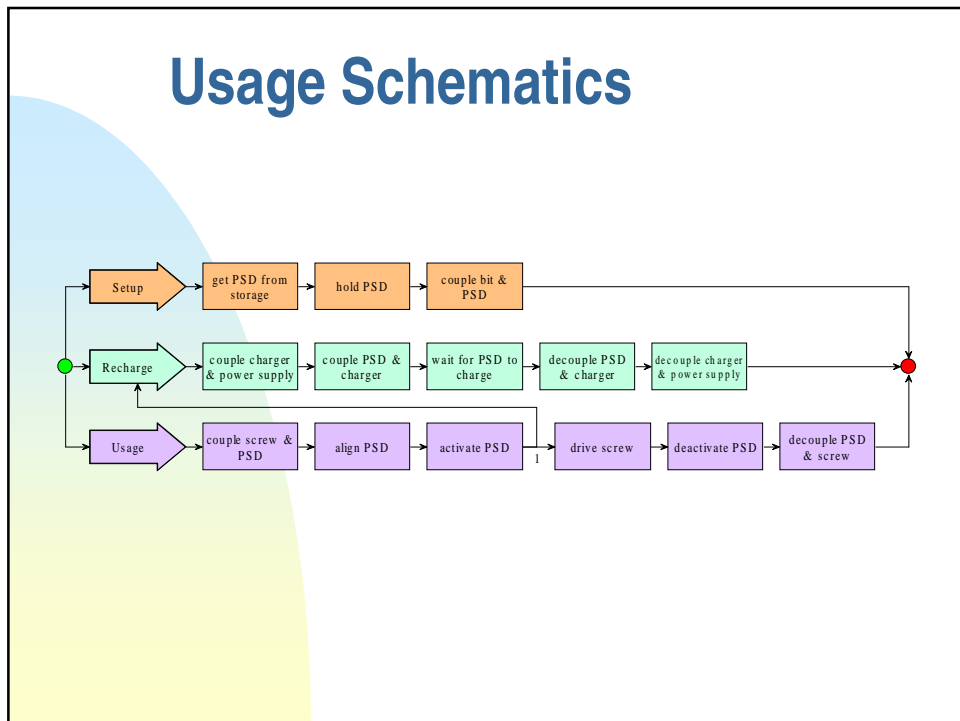
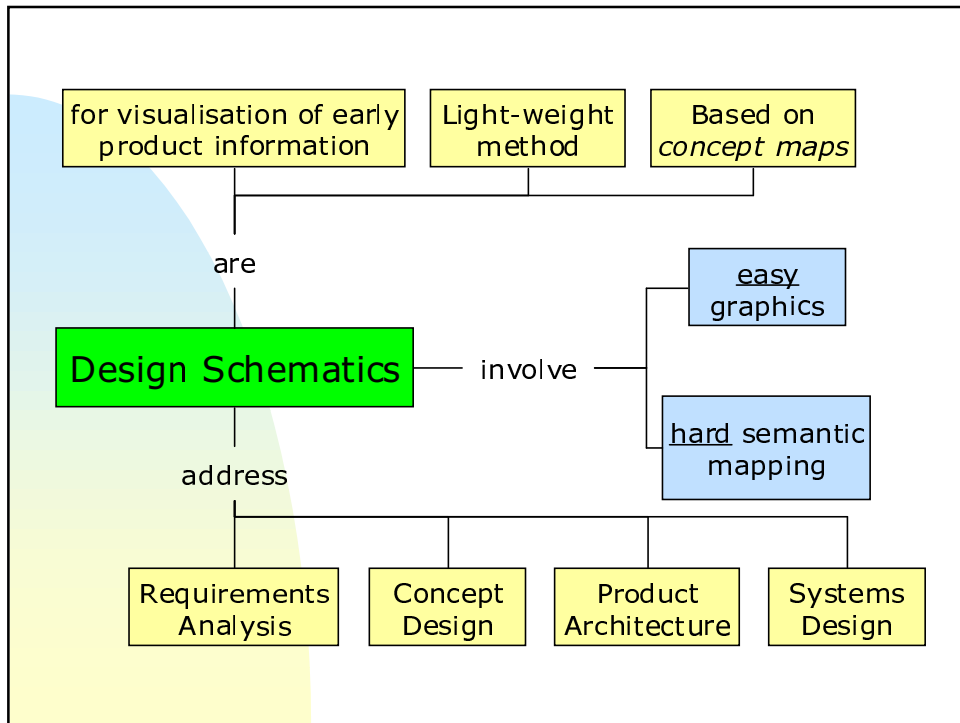

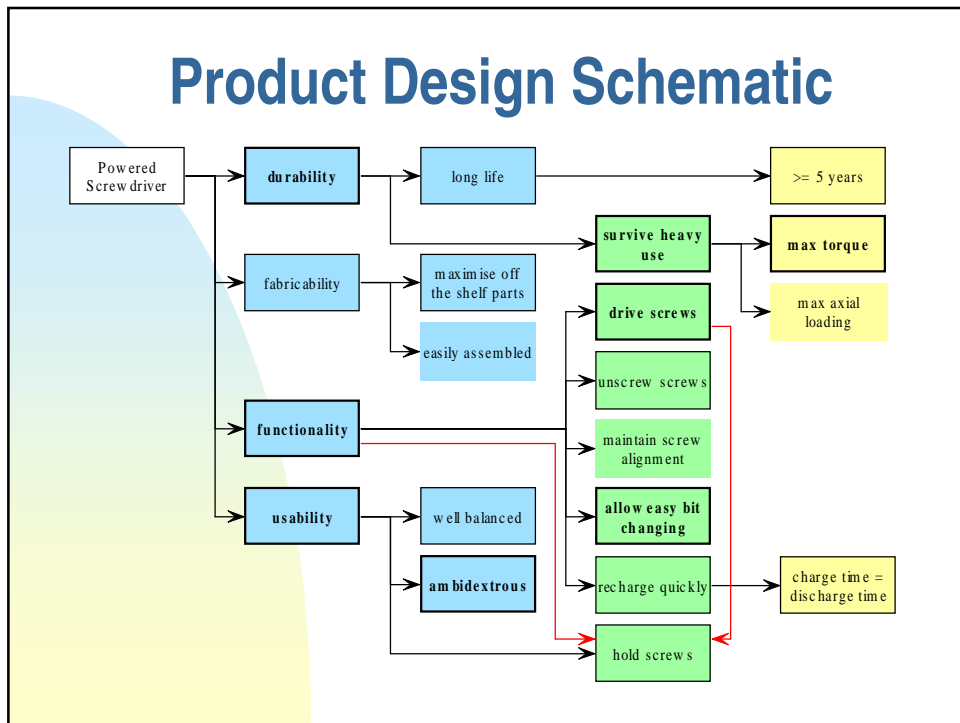
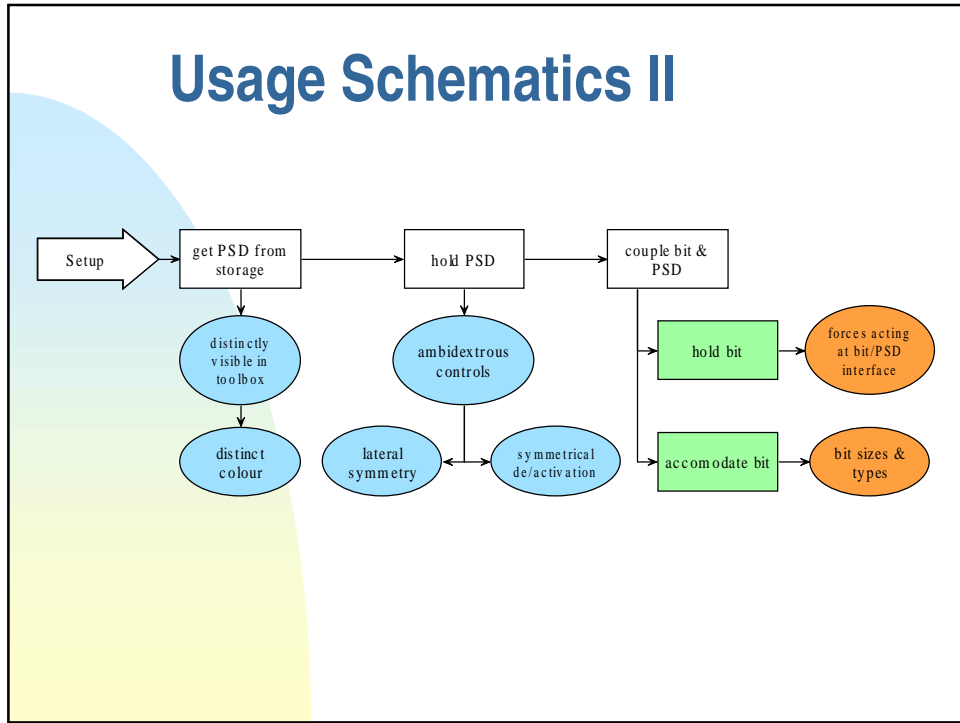

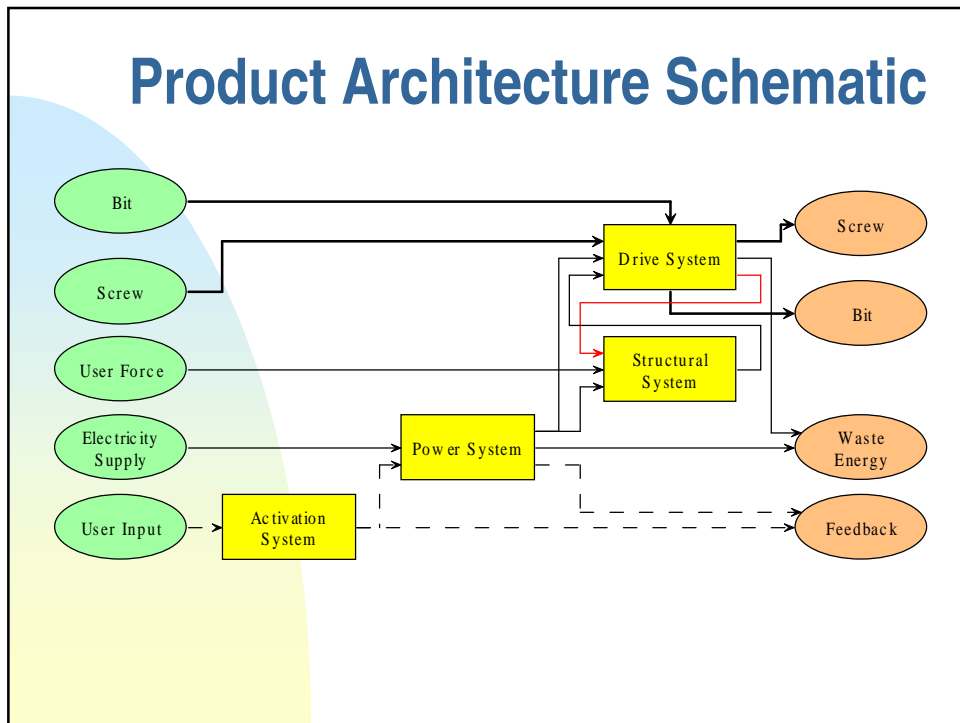
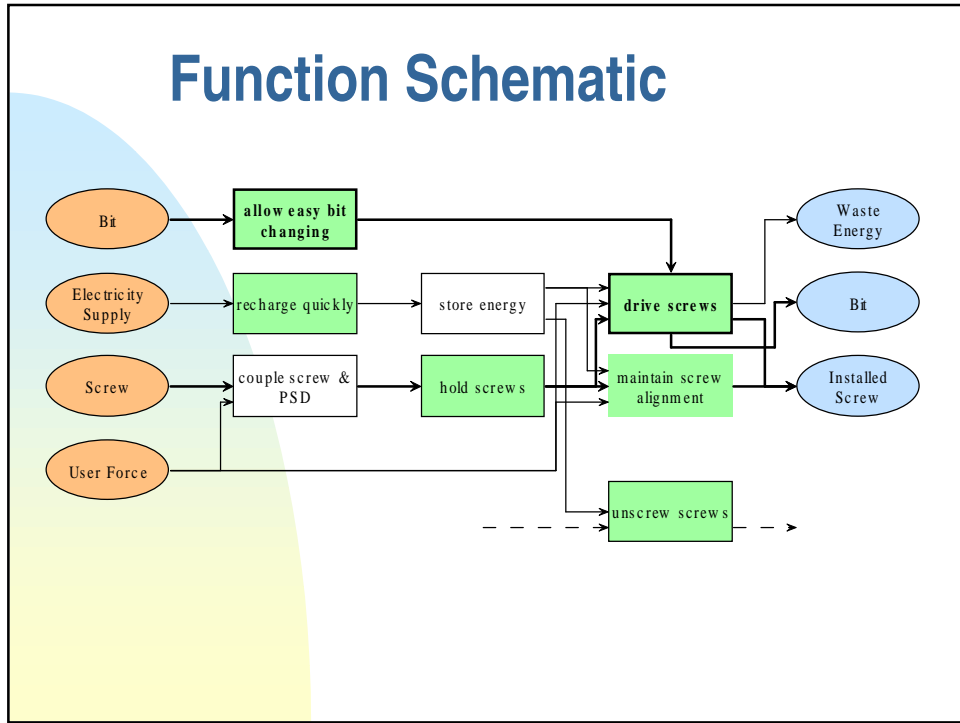



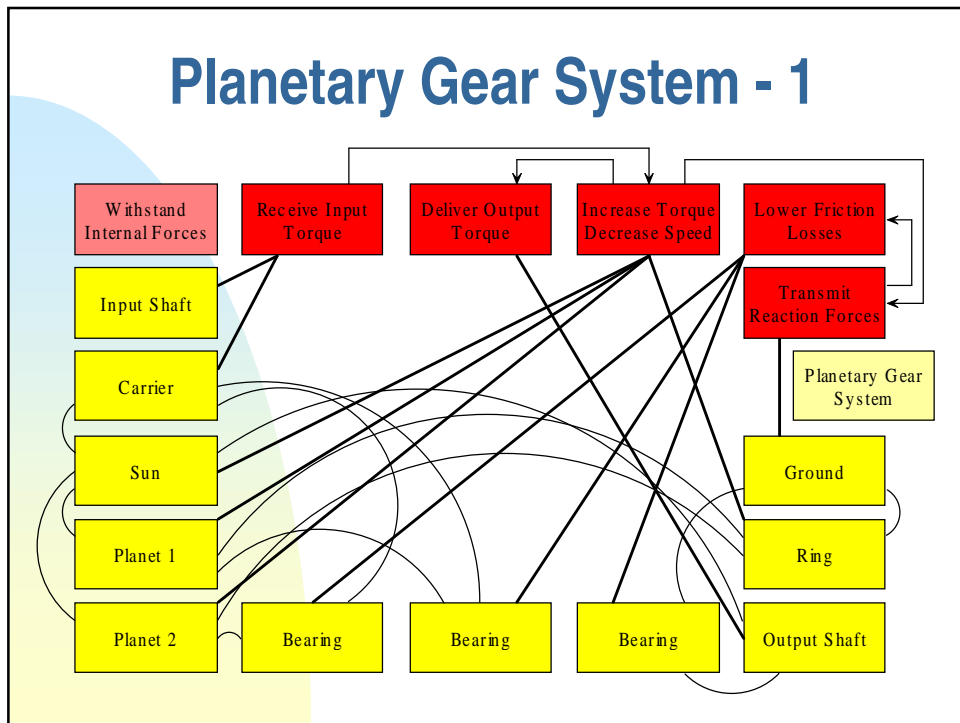
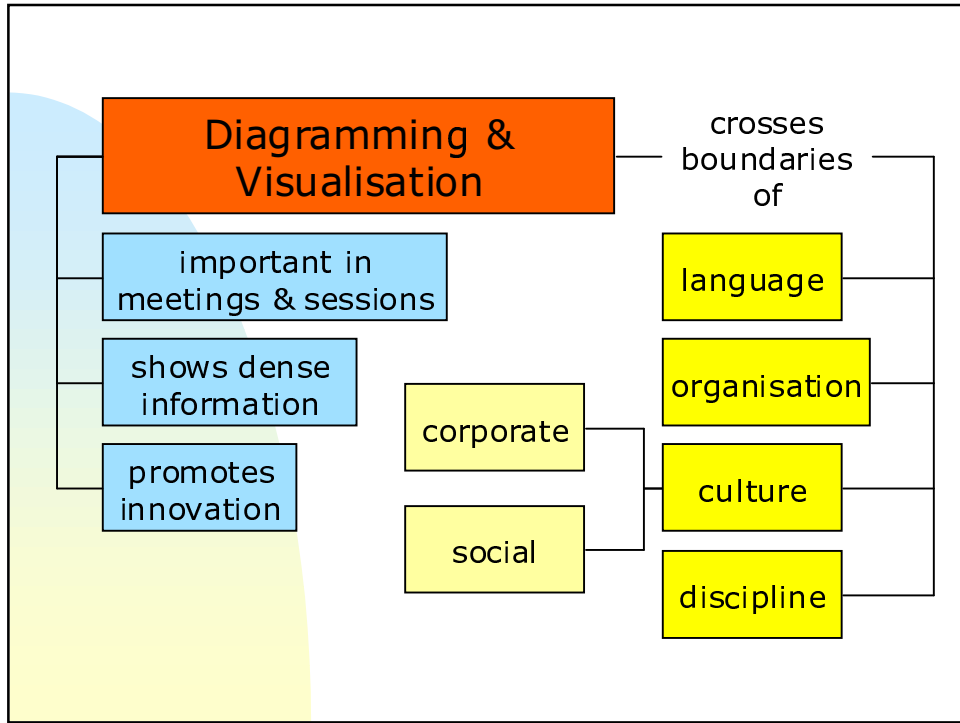

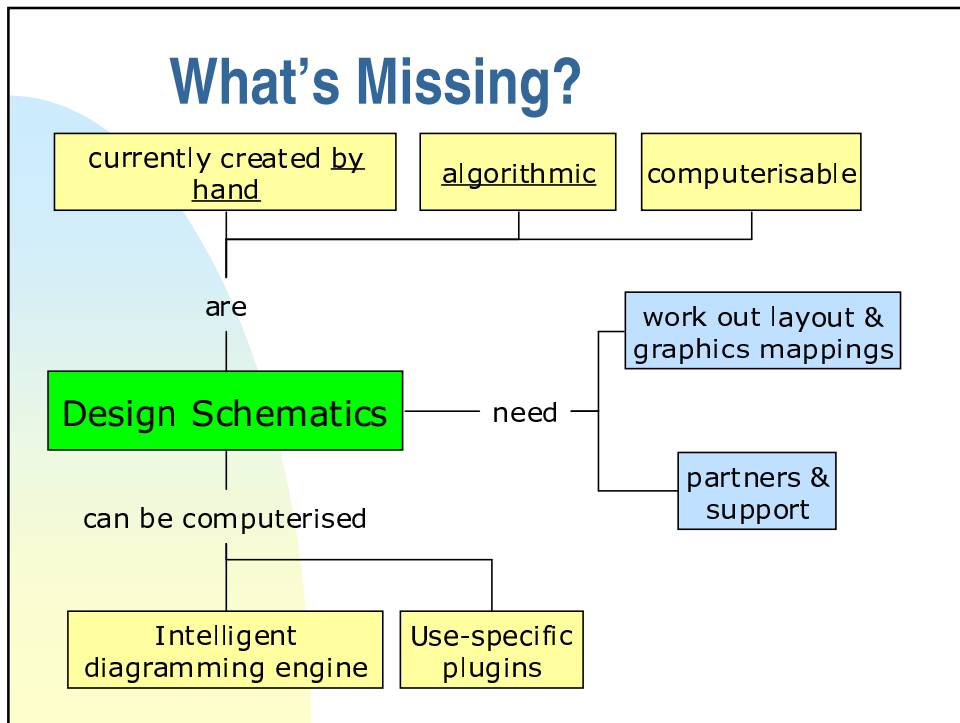
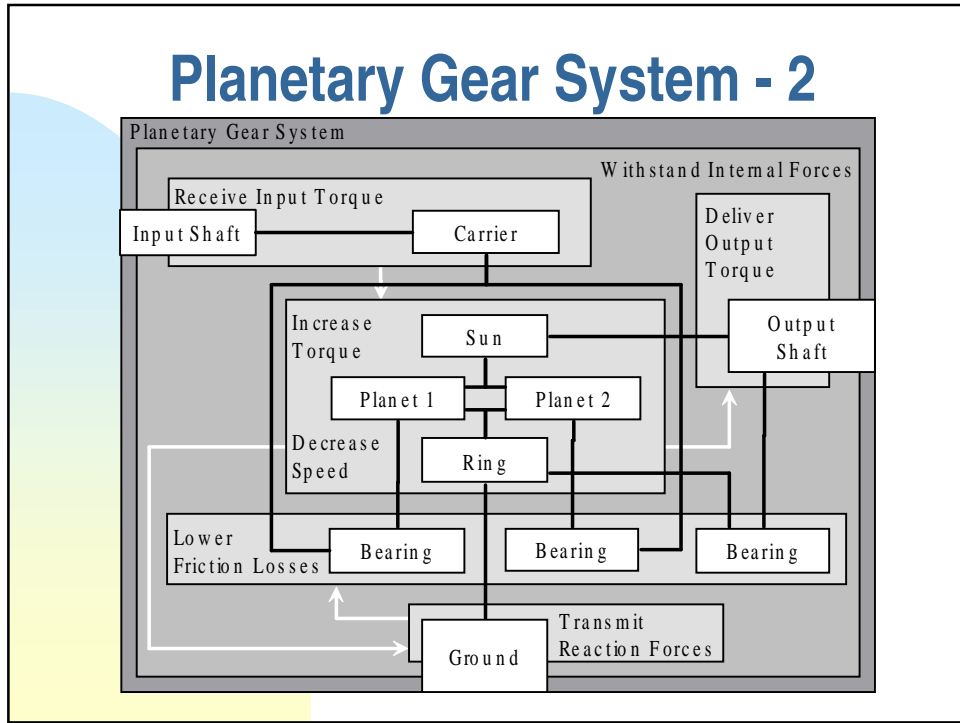

## Bridging the gulf

- 1999: IEEE Software ripped me apart
- 2003: a different tune
  - ◆ IEEE Software 23(2,3)
  - ◆ IEEE Computer 36(5)
- Canadian Design Engineering Network
  - ◆ <http://www.cden.ryerson.ca>
- design@ryerson
  - ◆ interdisciplinary design community